

Crown Actuated Valves & Controls

Protecting Your Personnel, Facilities, Environment and Natural Resources



Crown Self-Contained Hydraulic Valve Actuation System

Stream-Flo's Crown self-contained hydraulic valve actuation system is used for the automatic closing of gate valves on wellheads and flow lines under emergency conditions. The system consists of a hydraulic actuator, a manual hydraulic pump and control assembly, and a reverse-acting gate valve.

Crown Hydraulic Actuator and Reverse-Acting Gate Valve

1 Modular actuator is independently assembled and tested, enabling easy and quick replacement with minimal downtime.

2 No external tie rods, eliminates corrosion and improve safety.

3 Drift adjuster allows easy drift setting and locking, independent of actuator.

4 Relief valve ensures that spring canister is non-pressurized, enhancing personnel safety.

5 Safeguards to prevent produced fluid from entering actuator: metal-to-metal back seat; self-energized stem packing; bonnet assembly vent; additional upper stem seals.

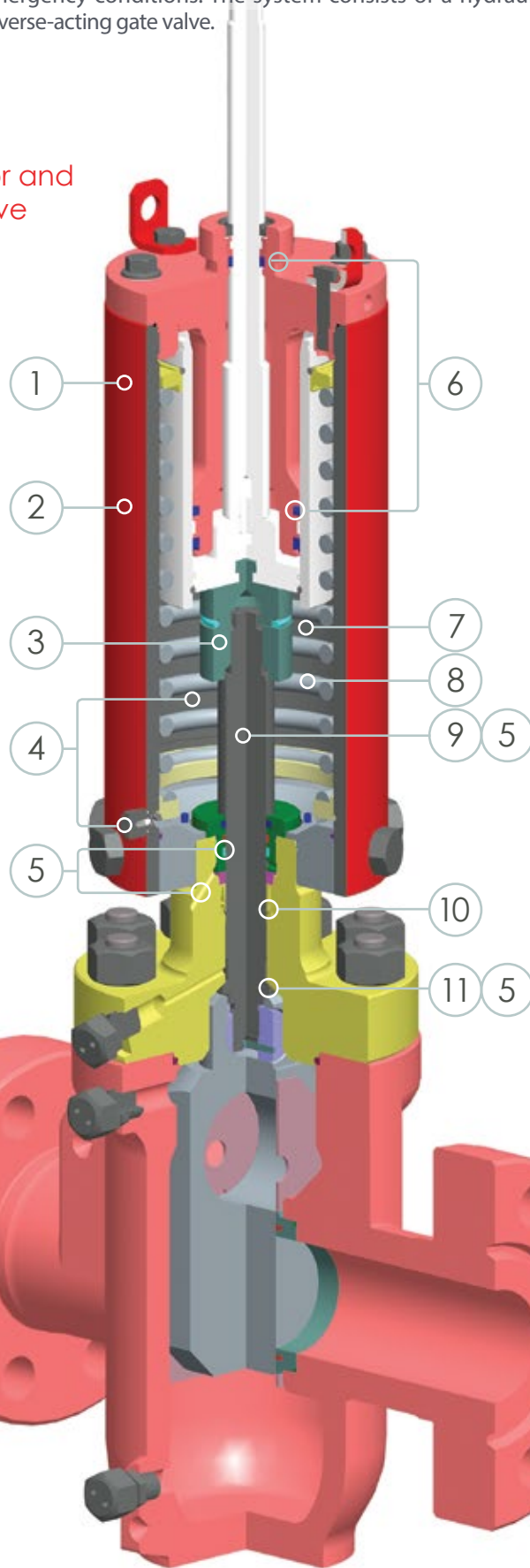

6 Replacement of actuator seals requires only the removal of the actuator head with no actuator removal needed.

7 Sealed spring canister and internals eliminate corrosion and reduces maintenance, spare parts and downtime.

8 Spring has one of the highest preloads for reliable shut in and is safely encapsulated within the spring canister to ensure the safety of personnel.

9 Optimized valve stem diameter providing reliable fail-safe valve operation.

10 Stem packing is self-energized ensuring reliable, long term maintenance free and bubble tight sealing.

11 Metal-to-metal stem backseat provides additional back-up sealing in the event of fire damage to the valve stem packing.



This valve actuation system is self-contained and releases no emissions to the environment. It requires no flow line pressure, compressed air, gases, nor electricity for power, and instead utilizes its own clean, contaminant-free, closed-loop hydraulics to power and control the actuation system. Instead of the control fluid being released into the atmosphere or emptied onto the ground, our system's hydraulic fluid is continually recycled and reused, protecting both operators and the environment. As a self-contained system, it is ideal for use in remote applications or in applications where a power source for an actuation system is not available, unreliable or is very costly to produce and/or maintain.

Crown Pump Control Unit with Reservoir

12

- Operates with clean non-contaminated hydraulic fluid.
- Bolt on reservoir ensures installation flexibility, enabling local or remote mounting of the Pump Control Unit.
- Closed hydraulic circuit moves clean hydraulic fluid from one component to the other, and does not release any produced fluid into the environment, promoting operator and environmental safety.

13

- Self-Contained Pump Control Unit, no external power source required.
- Modular design minimizes external tube and fitting connections.
- Easy change-out design, ease of service and minimizes down time.
- Pump Control Unit can be tripped by wide variety of tripping controls and can be integrated with existing SCADA and telemetry systems.
- Dual pressure circuit (high pressure) – Reduces actuator swept volume and provides best unassisted shut-down times in the industry; Reduces actuator overall size; Reduces the accumulator size, if needed.
- Dual pressure circuit (low pressure) – Highly repeatable Pilot settings not affected by varying control pressure; Allows use of more readily available, lower cost, bubble tight tripping control components; High capacity built-in mechanical accumulator to compensate for thermal fluid volume fluctuation, allowing more flexibility in the placement of tripping components.
- Stream-Flo manufactured, purpose-built and designed to zero-leakage standards.

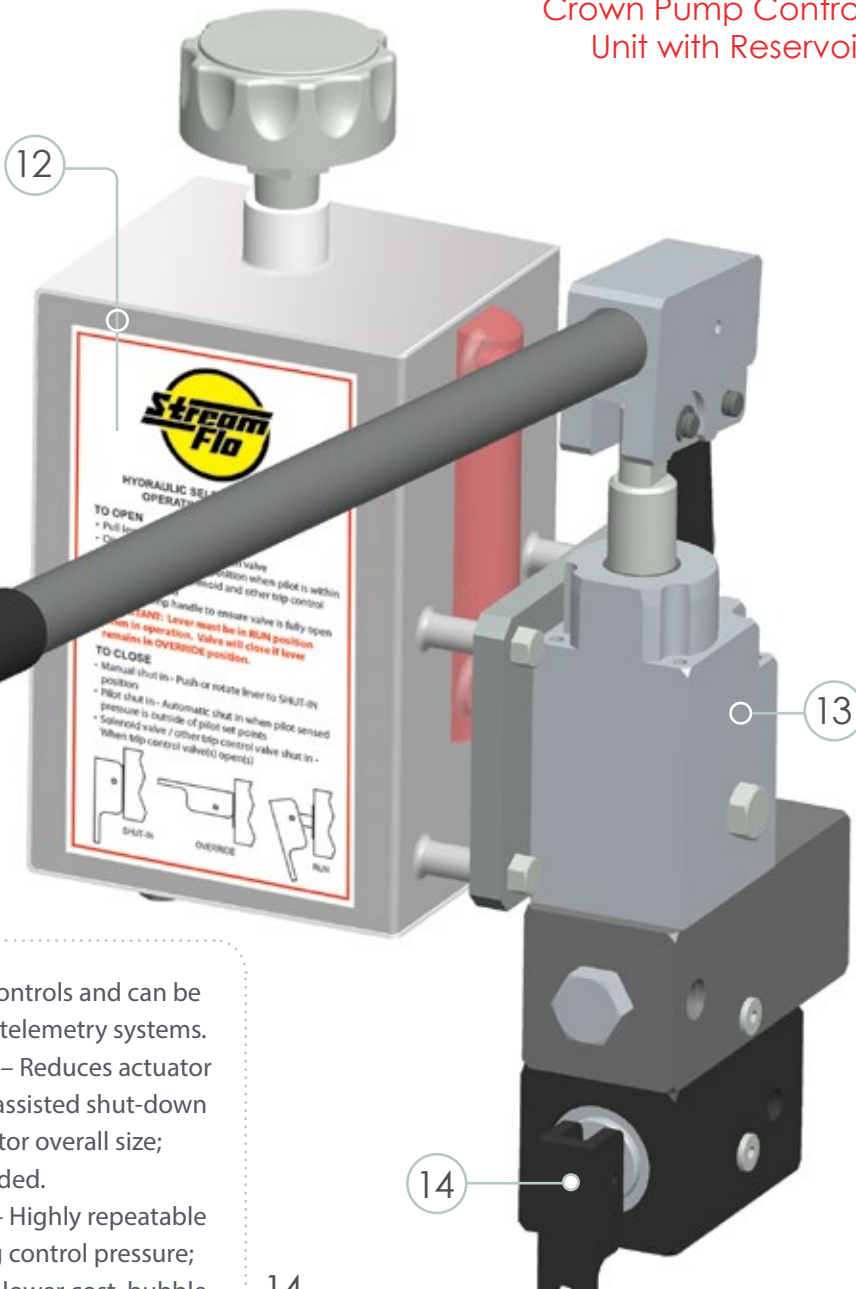

14

- Manual Override Valve latch automatically moves from *VERRIDE* to *RUN* when tripping controls are satisfied.
- Manual Override Valve will also automatically allow the system to move to the safe position if tripping controls are not satisfied.

Schematic & Specifications

Typical Hydraulic Schematic

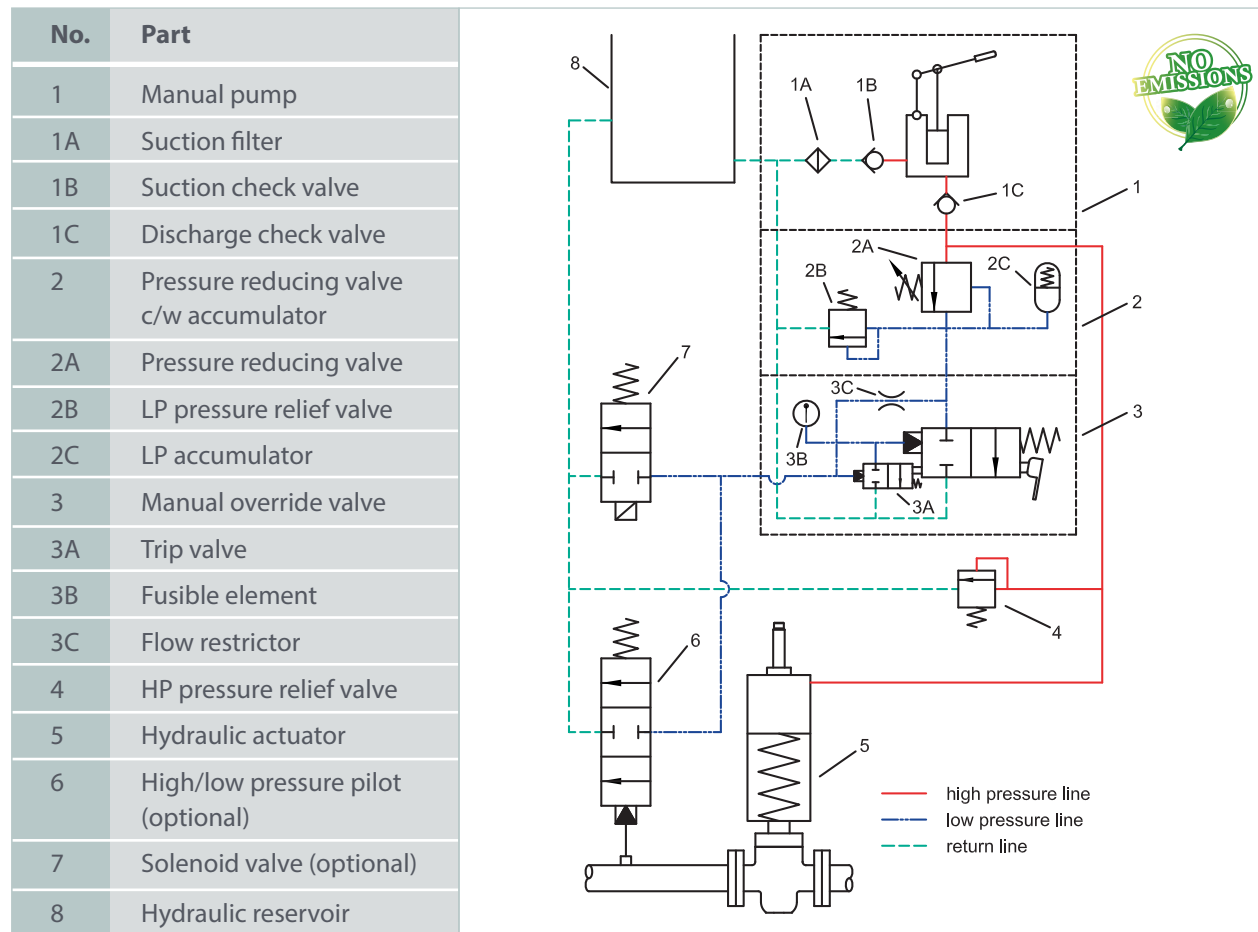

General Specifications*

Actuator	Maximum operating pressure Temperature range Operating media	3500 psi -50°F/-46°C to +180°F/+82°C Clean hydraulic fluid
Valve & Bonnet Assembly	Sizes API rated working pressures Temperature classifications Material classes Performance requirements Product specification levels Special requirements	1-13/16" to 11" To 20,000 psi K -75°F/-60°C to Y +650°F/+345°C AA to HH 1 and 2 (Annex F) 1, 2, 3, 3G and 4 Annex I (6AV1) Fire-safe design SIL 3 capable
Pump Control Unit	Temperature range Seals Component materials	-50°F/-46°C to +180°F/+82°C Teflon, polyurethane and nitrile Anodized aluminum and stainless steel

*General specifications only. Please contact Stream-Flo for other requirements.

Config2 Integrated Solutions

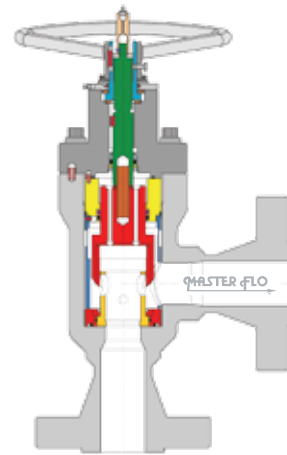

The Config2 was developed to address industry oil and gas safety needs and well protection requirements. Factory assembled and tested, the Config2 assembly provides compliance to the latest industry operational and safety standards.

A basic Config2 consists of an actuated gate valve assembly, choke/control valve, Access Tee, Pump Control Unit, Pilot, Isolation Valve, needle valve and pressure gauge. Other trip control devices such as a solenoid valve and pneumatic switching valve can be added to this configuration. The actuated gate valve is on the upstream end, and the Access Tee on the downstream end with the choke/control valve between these two components. All controls on a Config2 are completely mounted, tubed and tested.

Features

- Substantial savings on assembly and installation labor
- No field assembly, single crew installation
- No further field testing required
- Easier to handle on site
- No special skills/trades for installation or commissioning
- Lower transport cost due to smaller footprint
- Lower cost installed solution
- Single source for system design, quotations, purchase order placement, expediting, service and technical assistance
- Lower cost of ownership from better designs
- Access to engineering expertise and field experience through Stream-Flo and Master Flo
- Stream-Flo and Master Flo operate on a worldwide network of satellite locations for after-sales service
- Ability to customize product to meet specific site requirements

Benefits

- Combines the best technologies of Stream-Flo's proven valve actuation system design with Master Flo chokes
- Smaller foot print
- Lighter assembly
- Factory assembled
- Optimum flow capacity
- Adapted and pre-installed controls
- Automation options are available
- Optimized material selection
- Proprietary 5CB Tungsten choke trim

Individual Components

Stream-Flo's valve actuation system is designed to shut down a well automatically in the event of abnormal pressure fluctuations in the flow line due to fire, ruptured/plugged lines, surface equipment faults/failures, damaged wellheads or other causes.

Using Master Flo's external sleeve design choke:

- High controllability
- Superior sand-erosion resistance
- Independent shut-off capability
- Controlled body or outlet port erosion
- Linear flow into outlet
- Actuation options
- Applied fluid impingement principle
- Efficient high velocity jet control
- Hydro-dynamically efficient design

Accessories

Options can provide you more flexibility:

- Crown Access Tees
- Crown Pilot Isolation Valves
- Lock open devices
- Limit switches
- Crown electro-hydraulic Pump Control Units
- Crown valve actuation system / surface controlled subsurface safety valve Pump Control Units
- Crown remotely mounted Pump Control Units
- Indicator rod protectors
- Custom engineered spool pieces
- Theft proof enclosures
- Custom packaged actuation systems

The system can be triggered any way required, with the most common trigger being flow line pressure. Other triggers include:

- High and/or low pressure sensors
- Rate of pressure drop sensors
- Solenoid valves
- Temperature sensors
- Fire sensors
- SCADA signals
- Others

General Applications



Wellhead Actuated Valve Applications:

Conventional Wells:

- High Pressure
- High Temperature

Injection Wells:

- CO₂ Injection
- Steam Injection
- Miscible Flood Injection
- Water Disposal
- Water Flood

Gas Storage Wells

Other Actuated Valve Applications:

- Blowdown Valves
- Flow Lines
- High Integrity Protection Systems
- High Integrity Pressure Protection Systems
- Manifolds
- SIL Requirements
- Skids

Wellhead Control Panel Applications:

- Self-contained hydraulic or electro-hydraulic
- For single or dual completion wells
- For single or multiple surface actuated valves and/or surface controlled subsurface safety valves







Head Office and Manufacturing Facility
4505 – 74 Avenue
Edmonton, Alberta, Canada T6B 2H5
t 780.468.6789 | f 780.469.7724

Sales and Marketing Office
400, 202 – 6 Avenue SW
Calgary, Alberta, Canada T2P 2R9
t 403.269.5531 | f 403.266.3307

Stream-Flo USA Head Office
8726 Fallbrook Drive
Houston, Texas, USA 77064
t 832.912.1022 | f 281.653.1188

Worldwide
Canada, United States, United Arab Emirates, Kurdistan Iraq, Indonesia

www.streamflo.com

Stream-Flo Group of Companies



MASTER FLO